

E 6050 LM

PD18

DRIVEN PILES KIT

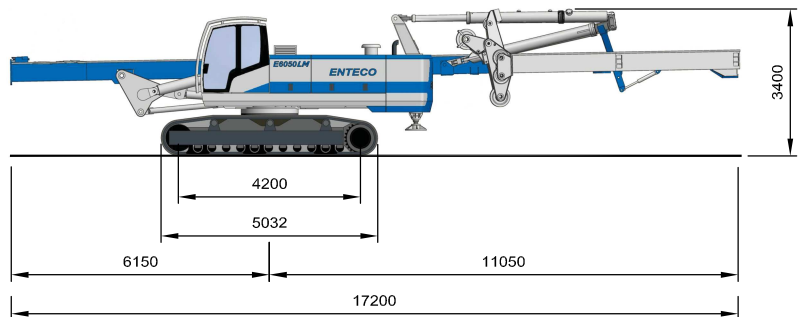
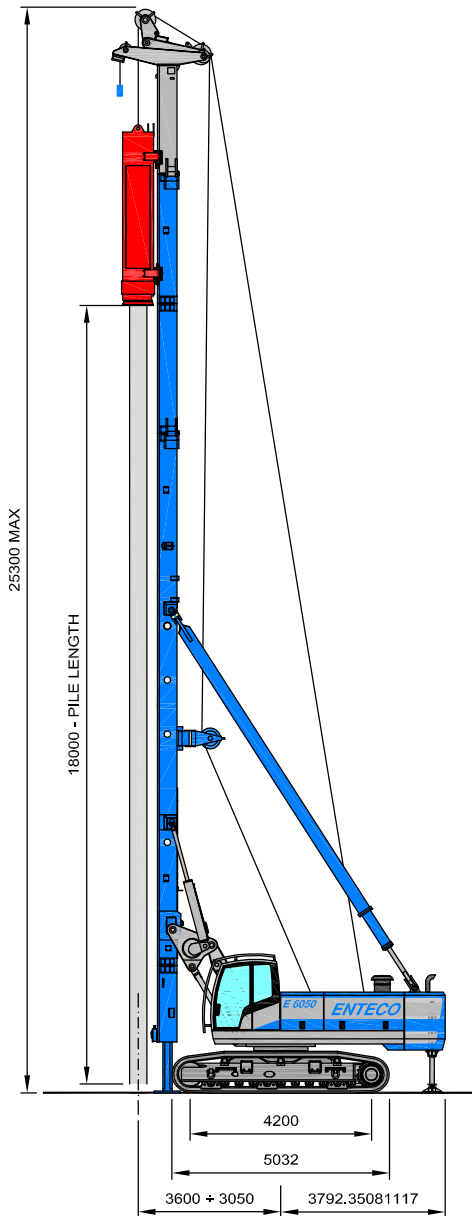

WIDTH: 3000 mm

E 6050 LM - PD18 DRIVEN PILES KIT

MACHINE WEIGHT

| | | |
|---------------------------------|----|-------|
| Operating weight without hammer | kg | 50000 |
| Operating weight with hammer | kg | 57000 |

HAMMER AND PILE

| | | |
|-------------------|----|------|
| Max hammer weight | kg | 7000 |
| Max pile length | m | 18 |
| Max pile weight | kg | 6000 |

MAST

| | | |
|------------------|----|-------|
| Mast length | mm | 22500 |
| Mast foot travel | mm | 1300 |

COUNTERWEIGHT

| | | |
|--------------|----|------|
| Total weight | kg | 6000 |
|--------------|----|------|

E 6050 LM - BASE MACHINE

CRAWLERS

| | | |
|----------------|------|----------------------|
| Overall width | mm | 3000+4200 |
| Track pads | mm | 700 |
| Tramming speed | km/h | 1,6 ÷ 2,5 (OPTIONAL) |

DIESEL ENGINE

| | | |
|--------------------|-------------|----------|
| Model | CATERPILLAR | C9 ACERT |
| Rated power | HP/kW | 350/261 |
| Fuel tank capacity | litres | 400 |

HAMMER WINCH

| | | |
|-------------------------|----|-----|
| Max line-pull 1st layer | kN | 165 |
|-------------------------|----|-----|

PILE WINCH

| | | |
|-------------------------|----|----------|
| Max line-pull 1st layer | kN | 70 |
| Free-fall device | | OPTIONAL |



Via dell'Artigianato, 33 - Z.I. - 30020 Fossalta di Piave - VENEZIA - ITALIA
Tel +39 0421 67.99.77 - Fax +39 0421 67.99.93 - e-mail: info@entecodrill.com - www.entecodrill.com

E6050 LM - PD18 090Q-363 20150710